

Foundational Research in the European Programmes

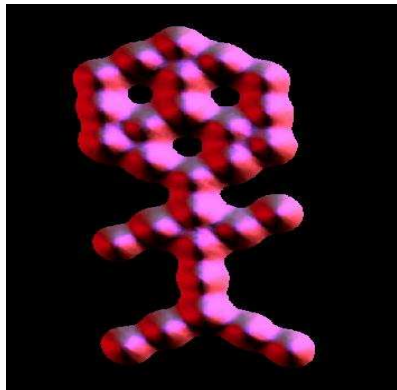

*Future and
Emerging
Technologies*



Outline

- Future and Emerging Technologies
- Examples of Projects
- Funding Research
- Impact Assessment
- Directions of Science and Technology in FP7
- Conclusion

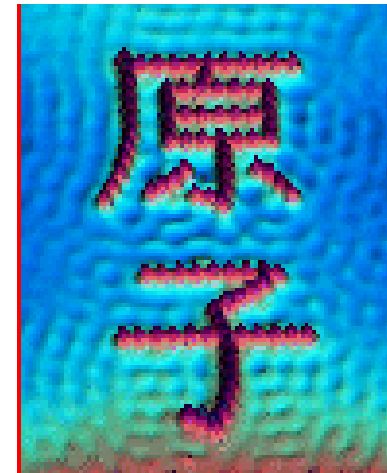

Future and Emerging Technologies (FET)

- EU Framework Programmes in ICT: tradition to support basic and long-term collaborative research.
- FET is a « pathfinder », exploring New Frontiers and building New Scientific Communities
- More visionary and Exploratory part of IST
- A « Nursery » of Novel Research Ideas
- High-Risk Research promising major Advances and Potential for Industrial and Societal Impact

Future and Emerging Technologies Implementation

- Proactive Initiatives – Fixed Calls
- FET-Open – Continuous Submission
- Budget: ~300 M€ (2003-2006)
 - ☞ 2/3 for Proactive, 1/3 FET-Open

FET Proactive Initiatives – FP6

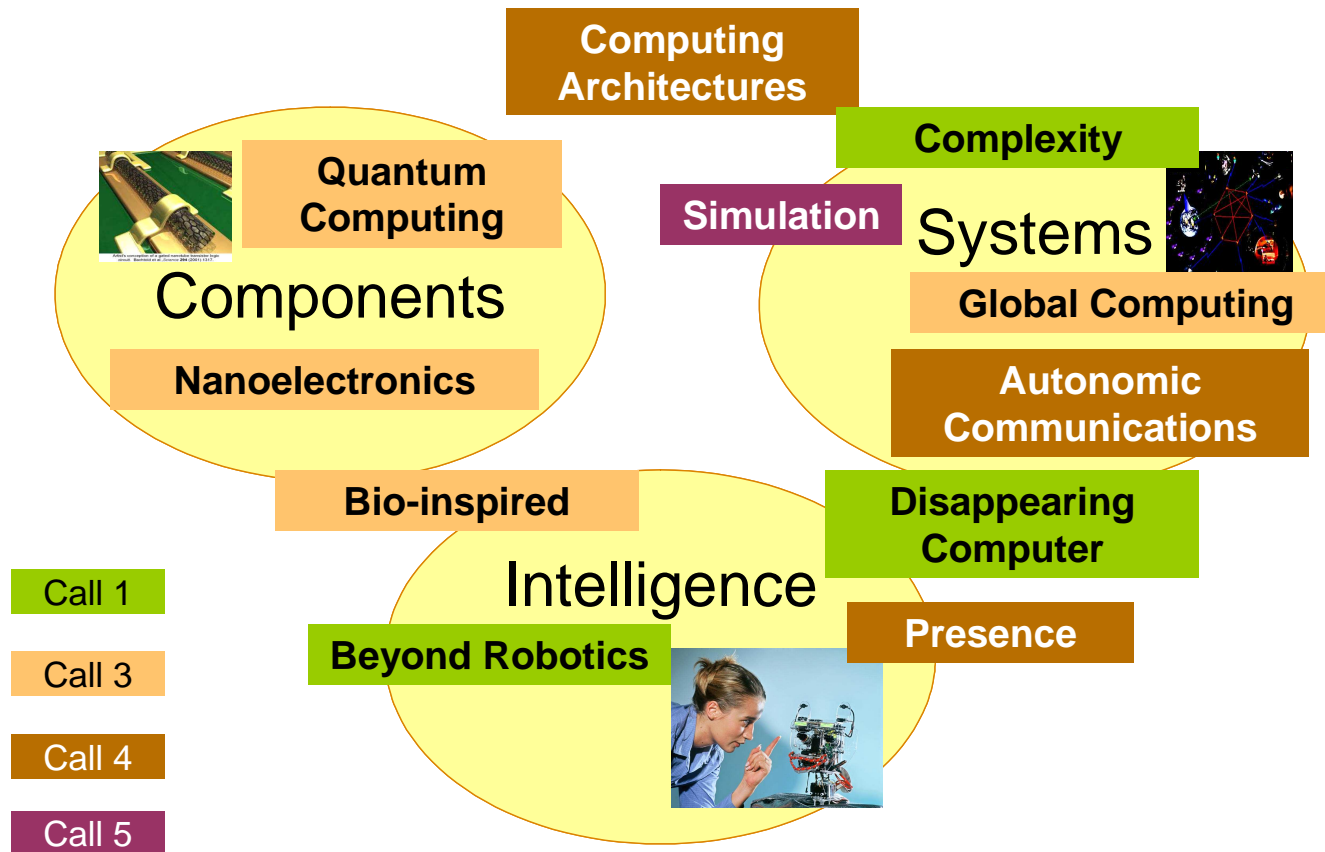

Future and Emerging Technologies

Proactive Initiatives in FP6

- ❑ Beyond Robotics (FP6-Call 1)
- ❑ Complex Systems (FP6-Call 1)
- ❑ The Disappearing Computer II (FP6-Call 1)
- ❑ Emerging Nanoelectronics (FP6-Call 3)
- ❑ Quantum Information Processing and Communication
(FP6-Call 3)
- ❑ GC - Global Computing II (FP6-Call 3)
- ❑ Bio-Inspired Intelligent Information Systems (FP6-Call
3)
- ❑ Advanced Computing Architectures (FP6-Call 4)
- ❑ Presence and Interaction in Mixed-Reality
Environments (FP6-Call 4)
- ❑ Situated and Autonomic Communications (FP6-Call

Future and Emerging Technologies

FET-Open in FP6

- ❑ ~1100 Short Proposals Submitted
- ❑ ~70 Full Proposals retained for funding
- ❑ 7% overall success rate (eligible proposals)
- ❑ 2B€ funding requested !!
- ❑ Wide-range of topics with emerging patterns
- ❑

FET-Open - Area coverage Funded STREPs (B1 – B8)

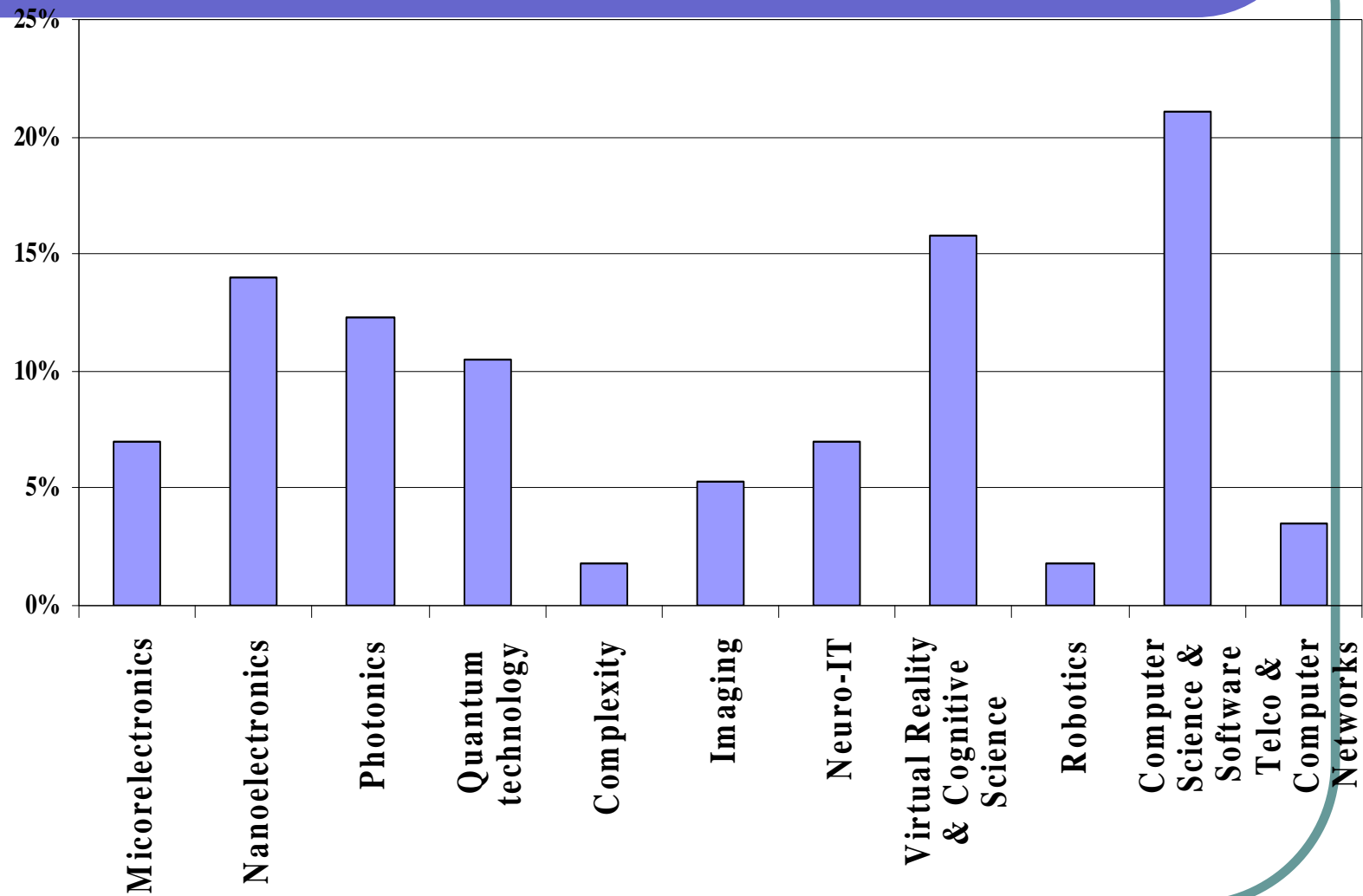

FET-FP5 Projects – NEAR 1/3

Objectives

**Applicability of
TBJs (Three-terminal Ballistic Junctions)
SSDs (Self Switching Devices)
to small scale integration (and even larger scale)**

Research methods:

- **design and realisation of circuits from simple logic ports to full-adders**
- **modelling and circuit simulations**
- **studies in buffering and cascading
experimental and by simulations (and by analysis)**

FET-FP5 Projects – NEAR 2/3

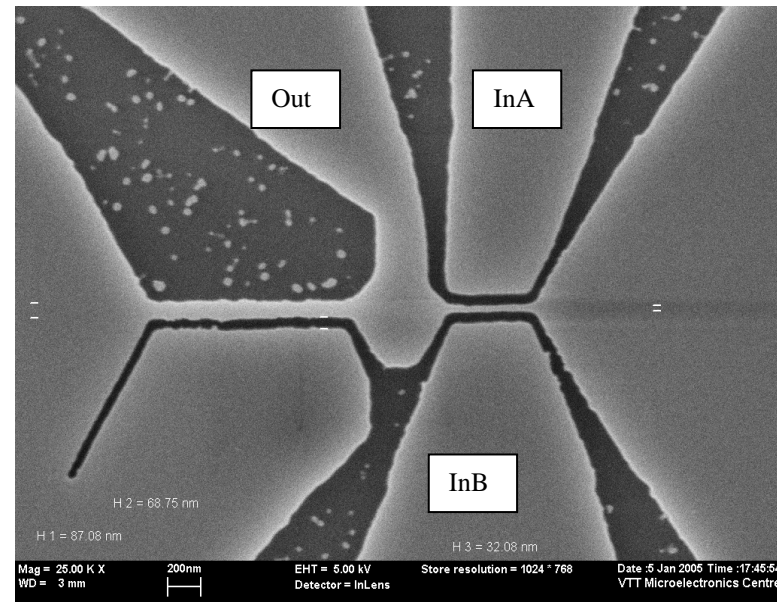
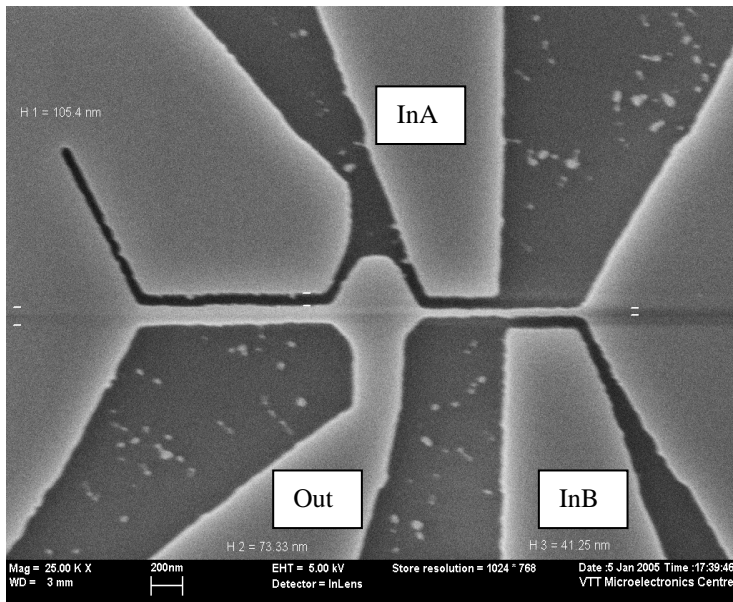

SEM images of a) NAND and b) NOR gates.

FET-FP5 Projects – NEAR 3/3

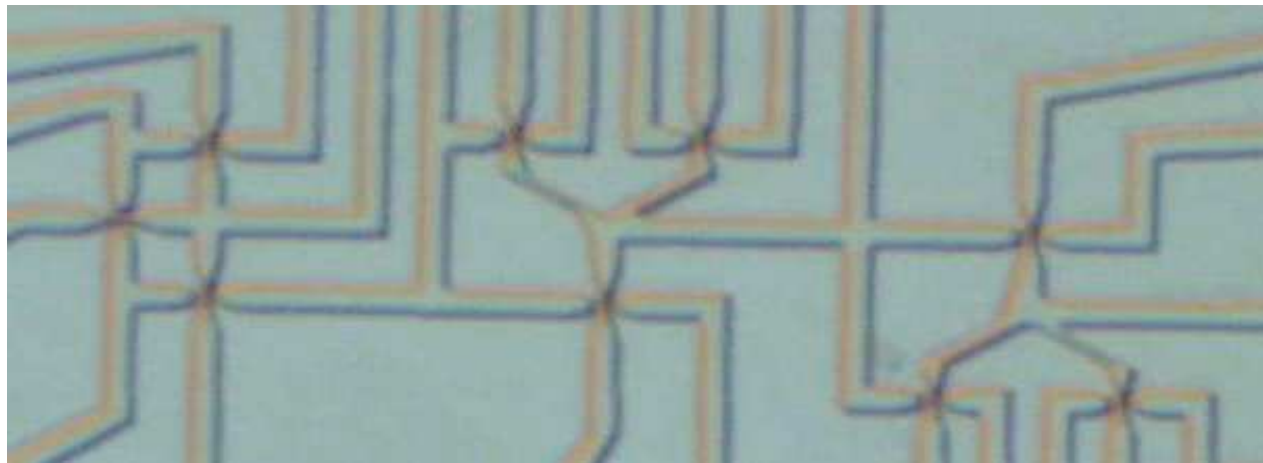
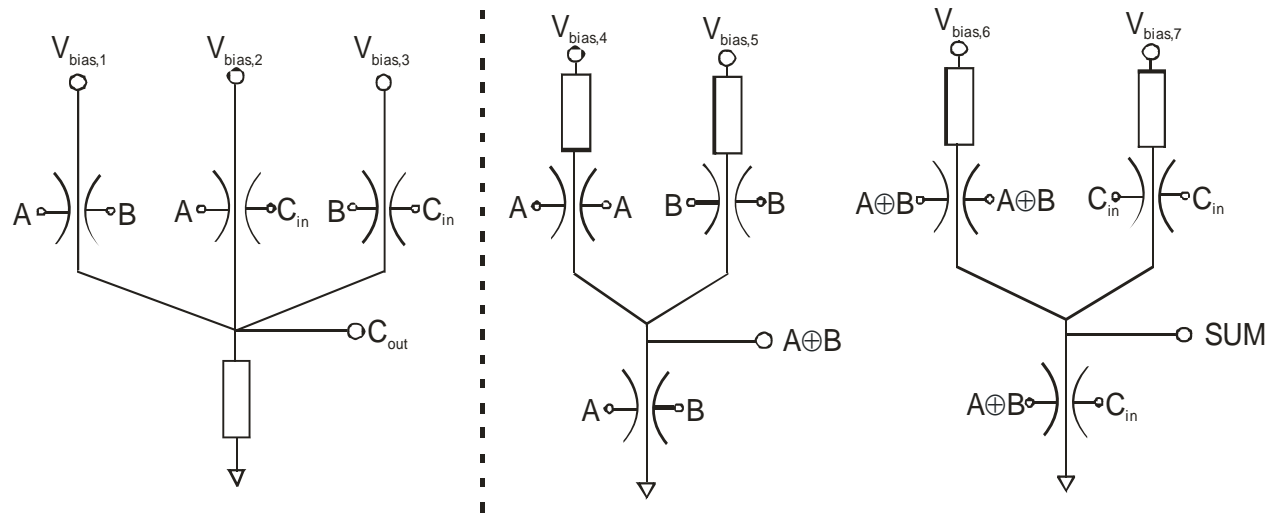

FET-FP5 Projects – CANVAD 1/2

Carbon Nanotubes for Microwave Vacuum Devices

Dream:

replace travelling wave tubes (TWTs) thermoionic cathodes by cold field emission cathodes using carbon nanotubes (CNTs) that, in principle, are able to directly emit electron bunches in response to an applied RF modulated field. With such cathodes a reduction of the weight and volume of TWTs by a factor of at least of 2 is anticipated (key aspect on satellites)

Objective:

The objective of this project was to demonstrate that CNT cathodes are able to deliver 1 A/cm² beams that can be modulated at frequencies up to 30 GHz.

FET-FP5 Projects – CANVAD 2/2

Carbon Nanotubes for Microwave Vacuum Devices

Results

- Highly uniform arrays of carbon nanotubes (5 μm height and 50 nm diameter) have been grown
- 100 μA from a single carbon nanotube has been obtained
- 12A/cm² peak current density at 1.5GHz
- The output peak current at the anode reached 30 mA
- 32 GHz beam modulation has been performed in a triode made of two resonant cavities.
- The very first results showed a modulated peak current of 0.3 mA (depth modulation of 40%) corresponding to a current density of 0.12A/cm².

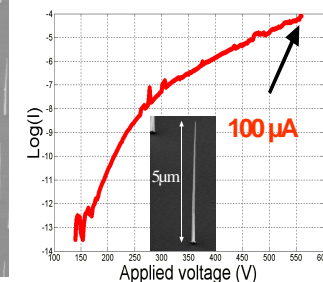
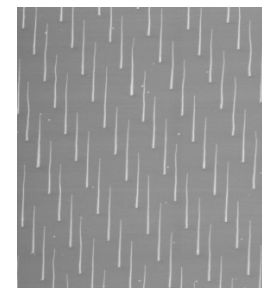
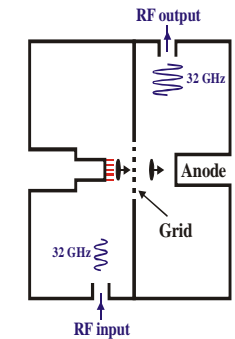
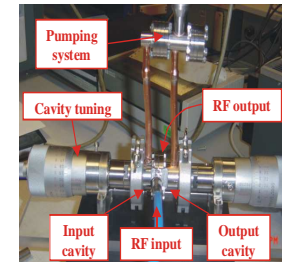
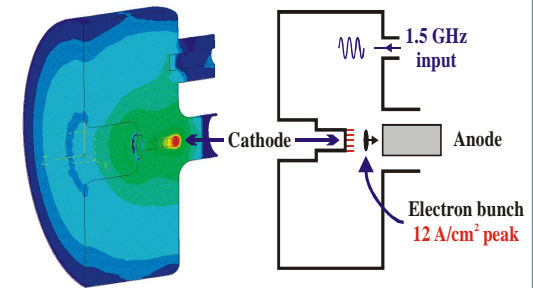

FEF-FP5 projects – Mol Switch 1/2

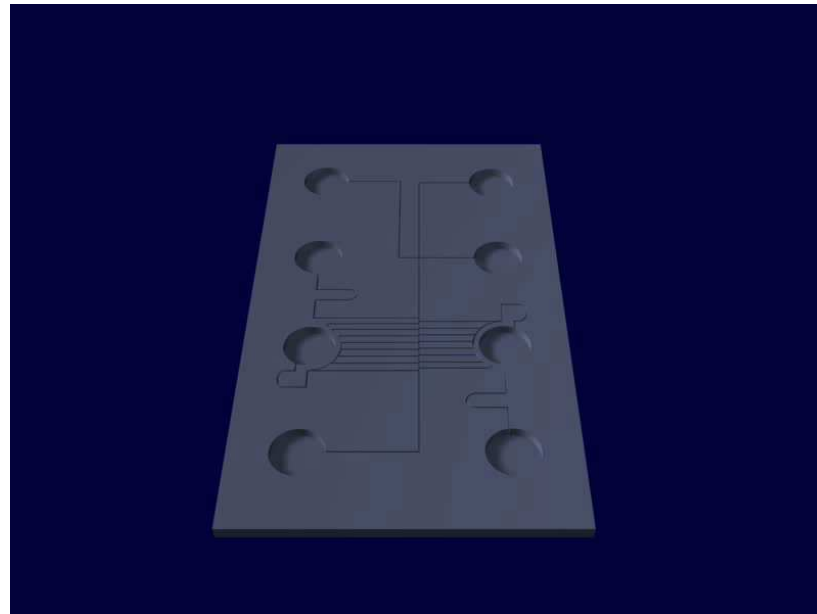

FEF-FP5 projects – Mol Switch 2/2

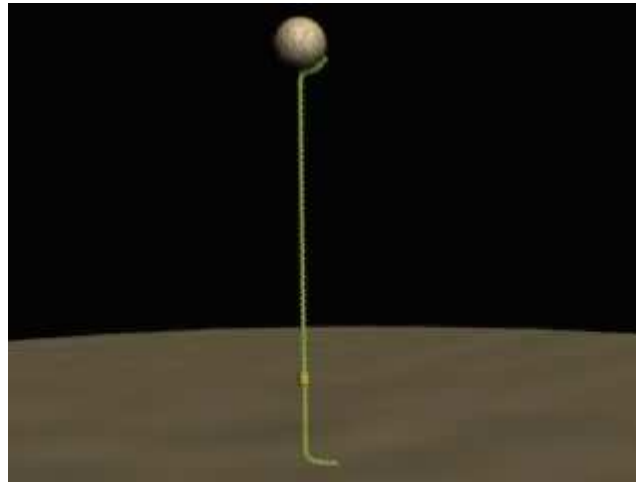

Nano-Electronics in FET: Status

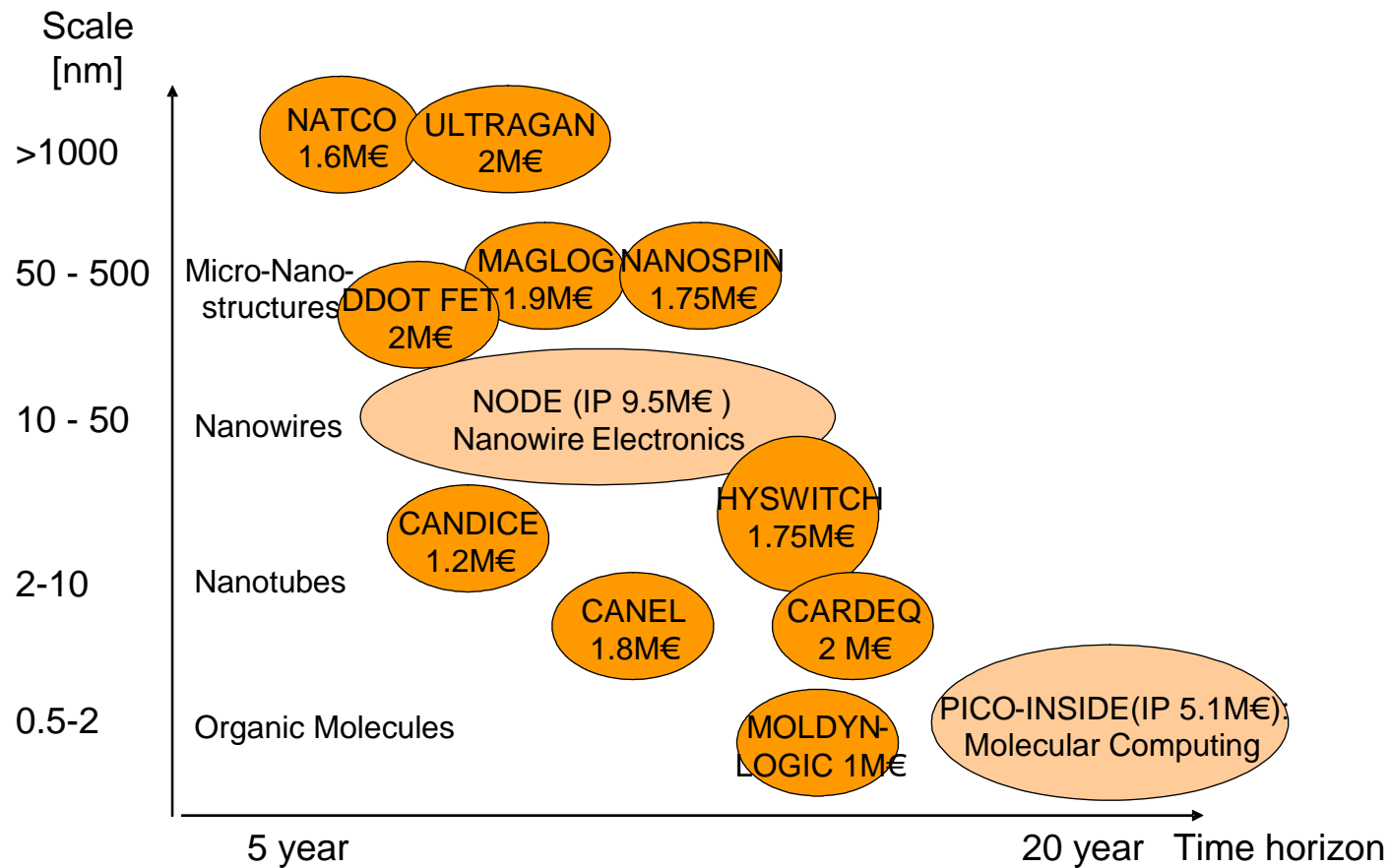

FP 6 projects, Σ 32M€

Funding research at European Level

Future and Emerging Technologies in IST

- 1. Framework Programme**
- 2. Scope of Areas and Themes**
- 3. Instruments**
- 4. Constituency**
- 5. Impact**

Funding research at European Level

Future and Emerging Technologies in IST

1. **FP7: 2007-2013**
2. **Scope of Areas and Themes: WP**
3. **Instruments: fixed from Pgm start**
4. **Constituency: continuous process**
5. **Impact Assessment !!**

Funding Research – FET Rationale

- (1) the appropriate timing for consolidating emerging research topics,
- (2) the existence of early critical mass,
- (3) the potential for long-term industrial exploitation and high societal benefits and, in some cases,
- (4) the possibility of focus in order to avoid very high over-subscription

Funding research - FET Objectives

- FET:**
- driven by excellence
 - purpose-driven collaborative research
 - high-risk, long-term, high-potential for S&T and societal impact
 - interdisciplinary

Funding research – FET World

- **2/3 Academic**
- **1/4 Research Centers**
- **1/10 Industry**

Funding Research - Impact Assessment

- Evaluation of Proposals
- 5-yr Programme Evaluation Exercise (1999-2003)
- Publications (magazines, books, reports)
- Citations (Researchers & FET-IST programme)
- Conferences/Workshops
- Awards
- Start Ups
- New programmes (Intl, EU, National)
- Ex-post impact assessment

Funding research – Impact Assessment Figures

Awards:

- **Prof. Theodor Hänsch** wins the Nobel Prize in Physics 2005
(FET projects ACQUIRE and ACQP)
- **Prof. Peter Zoller** receives The Niels Bohr Gold Medal of UNESCO (ERA-Pilot QIST and SCALA)
- **Alain Aspect** wins the Medaille d'Or of the CNRS (FET projects ACQUIRE, ACQP, and SCALA)
- **Christian Joachim** wins Feynman Prize in Nanotechnology (FET Integrated Project *Pico-Inside*)

Funding research – Impact Assessment Figures

Publications:

- *at least **42 publications** in the prestigious **Nature** and **Science** journals during 2000 – 02.*

Areas moving away from the FET portfolio:

- Quantum Cryptography
- Nanotechnologies (NMP programme)
- Advanced Microelectronics
- Advanced Information Interfaces

Monitoring of individual Projects/ Proactive Initiatives

FP7 – The Process in FET

- Interaction with stakeholders
- Collected in ERCIM “Beyond the Horizon” action
- Supported by ongoing consultations

FP7-FET - Beyond The Horizon

- An IST/FET Funded Coordination Action
- Coordinated by ERCiM
- 1/1/2005 – 30/6/2006 (www.beyond-the-horizon.net)

Objectives

- Identify strategic ICT-related S&T challenges - Design roadmaps
- Identify boundaries between “pure ICT” and other disciplines
- Active participation sought in “online communities”

Beyond the Horizon TGs

- Pervasive Computing and Communications – 3 Challenges
- **Nanoelectronics and Nanotechnologies – 6 Challenges**
- Security, Dependability and Trust – 3 Challenges
- Bio-ICT Synergies – 3 Challenges
- Intelligent and Cognitive Systems – 4 Challenges
- Software Intensive Systems – 3 Challenges

Additional challenges from

- Quantum Information Processing and Communication
- Complexity Research
- Systems Research
- Presence
- Tera Device Computing
- ...

Beyond the Horizon TGs - Challenges

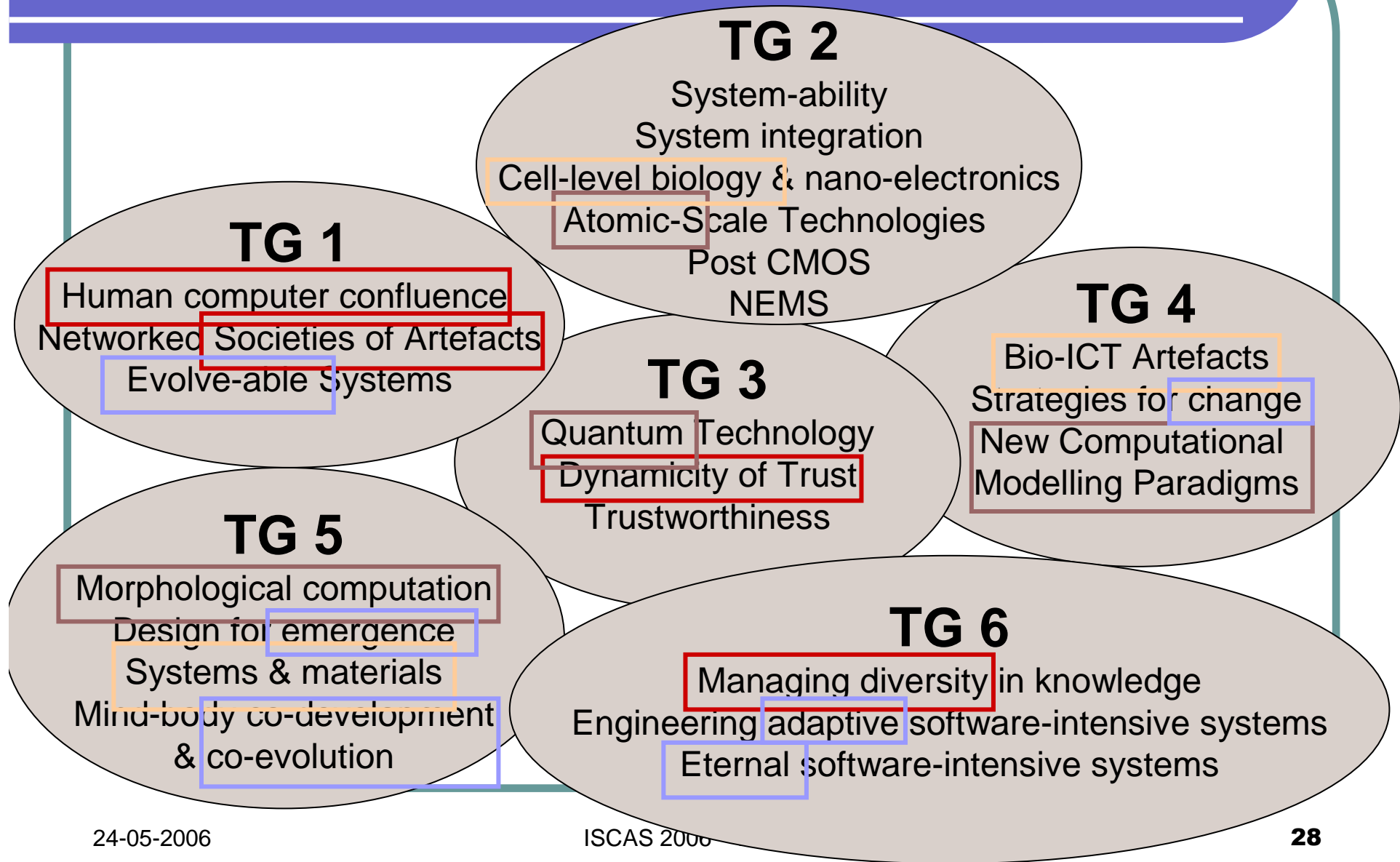

Techno and techno-social system challenges

Challenges related to the nature of computing

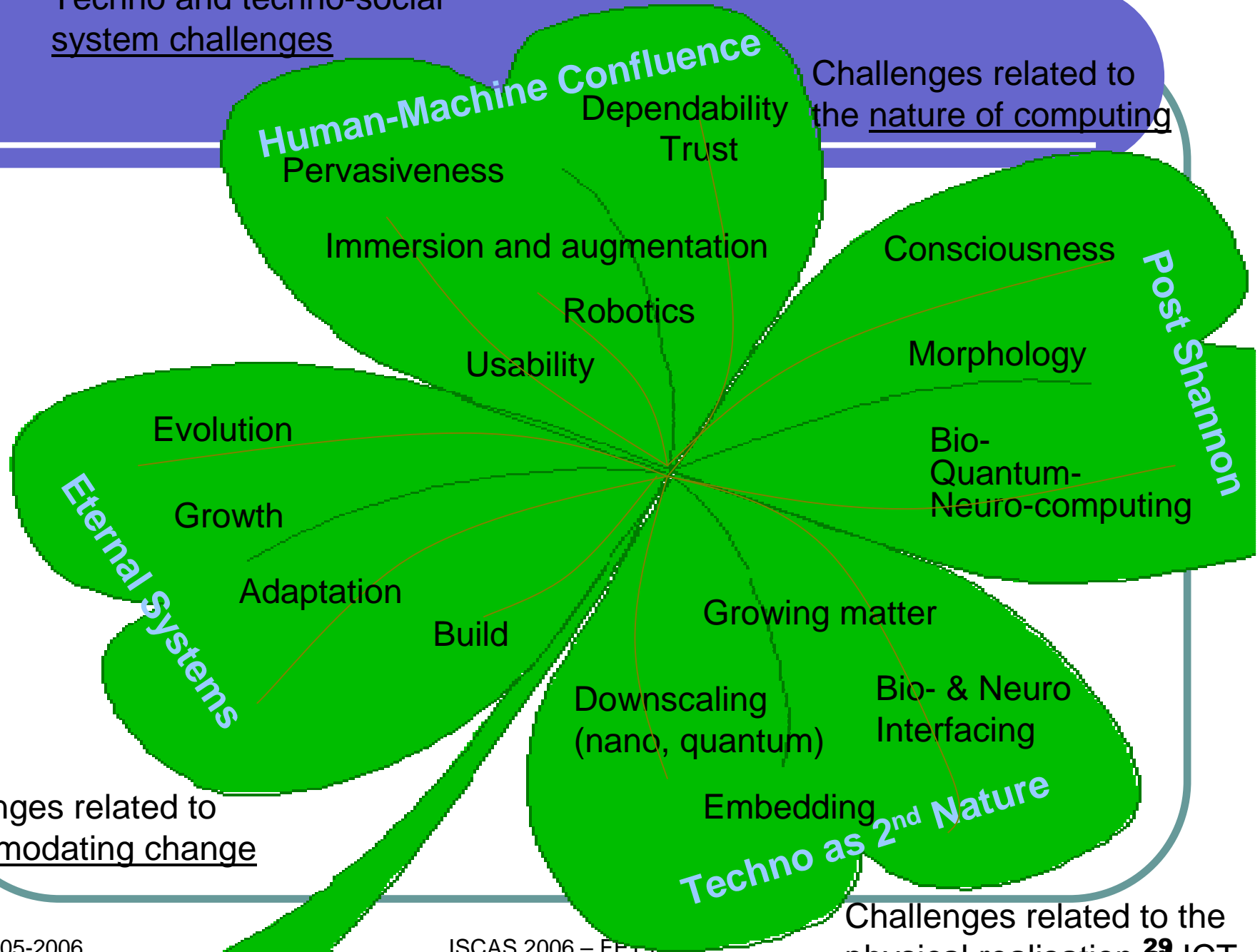

Challenges related to accommodating change

Challenges related to the physical realisation of ICT

Public Consultation

- February to April 2006
- Wide invitation:
 - EU-25 and beyond
 - ERCIM members
 - FET projects and experts
 - National and regional foundations and councils, government organisations
 - Major research organisations
- Consolidation of Responses Completed
- Brochure: Executive Summary + Full Report
- Dissemination of results May to November

See <http://www.cordis.lu/ist/fet/id.htm>

Directions of Science and Technology – FP7 (2007-2013)

- **Context:** Knowledge is at the core of the Lisbon agenda, and underpins all its elements. *Research and technology* are, together with *education* and *innovation*, the components of the “Triangle of knowledge”.
- **4 Specific Programmes**, corresponding to four major objectives of European research policy.

FP7 – Specific Programmes

Cooperation: Collaborative Research projects and networks - coordination of research programmes - international cooperation between the EU and 3rd countries

Ideas: An autonomous European Research Council to support investigator-driven “frontier research” carried out by individual teams competing at the European level, in all scientific and technological fields.

People: Reinforcement of “Marie Curie” actions, with a better focus on the key aspects of skills and career development and strengthened links with national systems.

Capacities: Support to key aspects of European research and innovation capacities - research infrastructures - research for the benefit of SMEs; regional research-driven clusters - unlocking the full research potential in the EU’s “convergence” regions - “Science in Society” issues; horizontal” activities of international co-operation.

FP7 Specific Programmes

(Proposed funding = 54.8 B€)

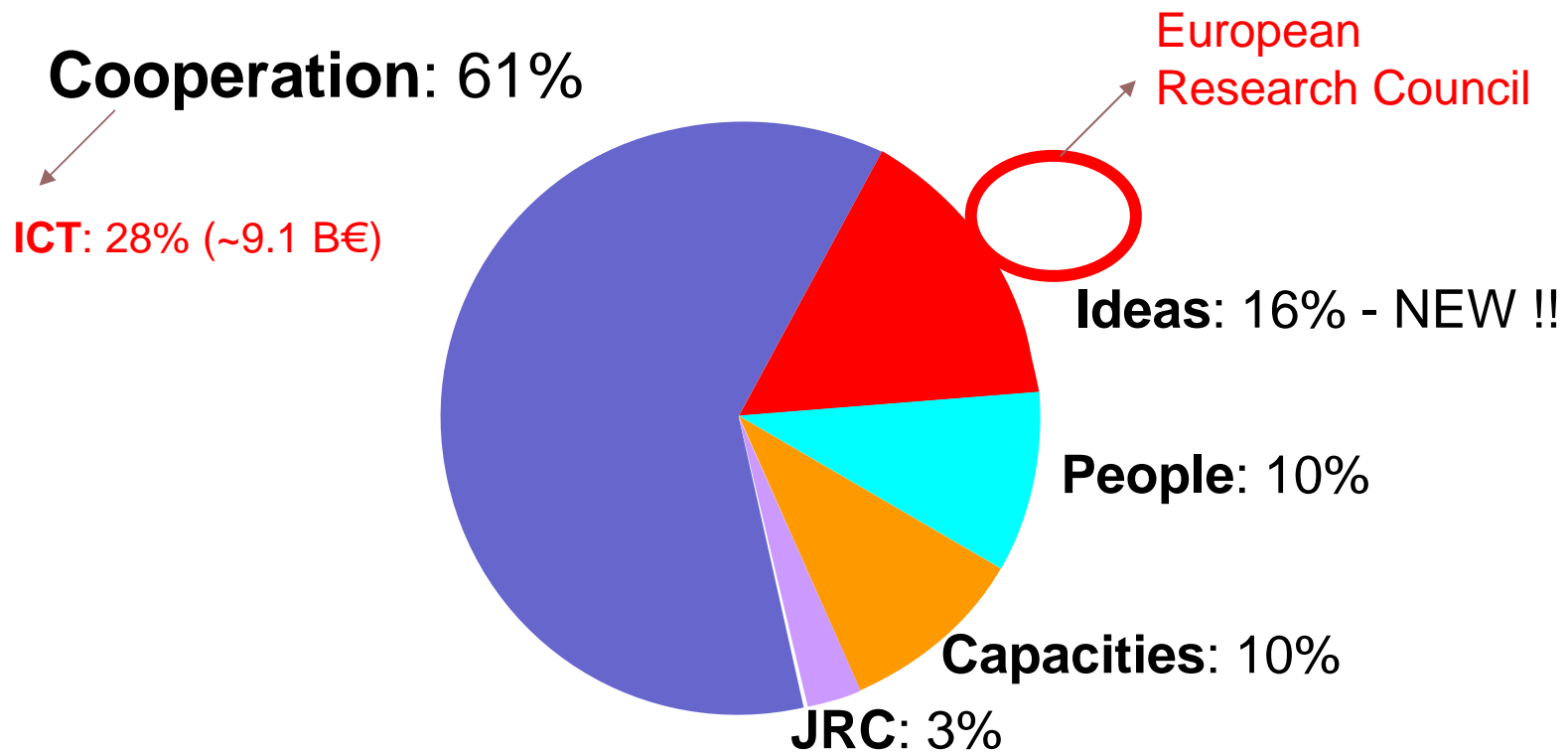

FP7 – Cooperation Themes

FET (10% of ICT)

**ICT
(28%)
(1.3 B€/year)**

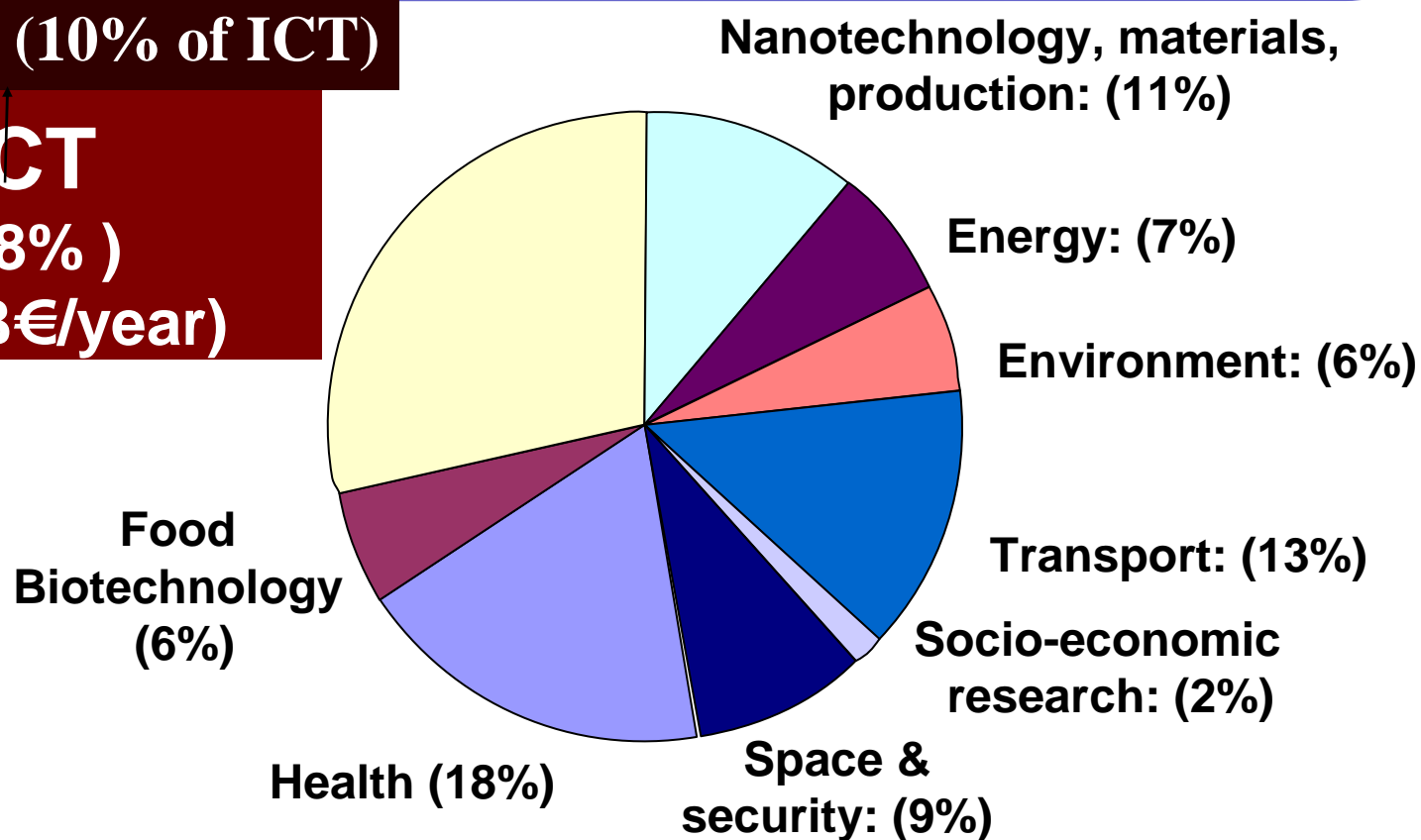

ICT is managed by Directorate for IT & Media (INFSO)

All other themes are managed by Directorate for Research (RTD)

FP7 – ICT Structure

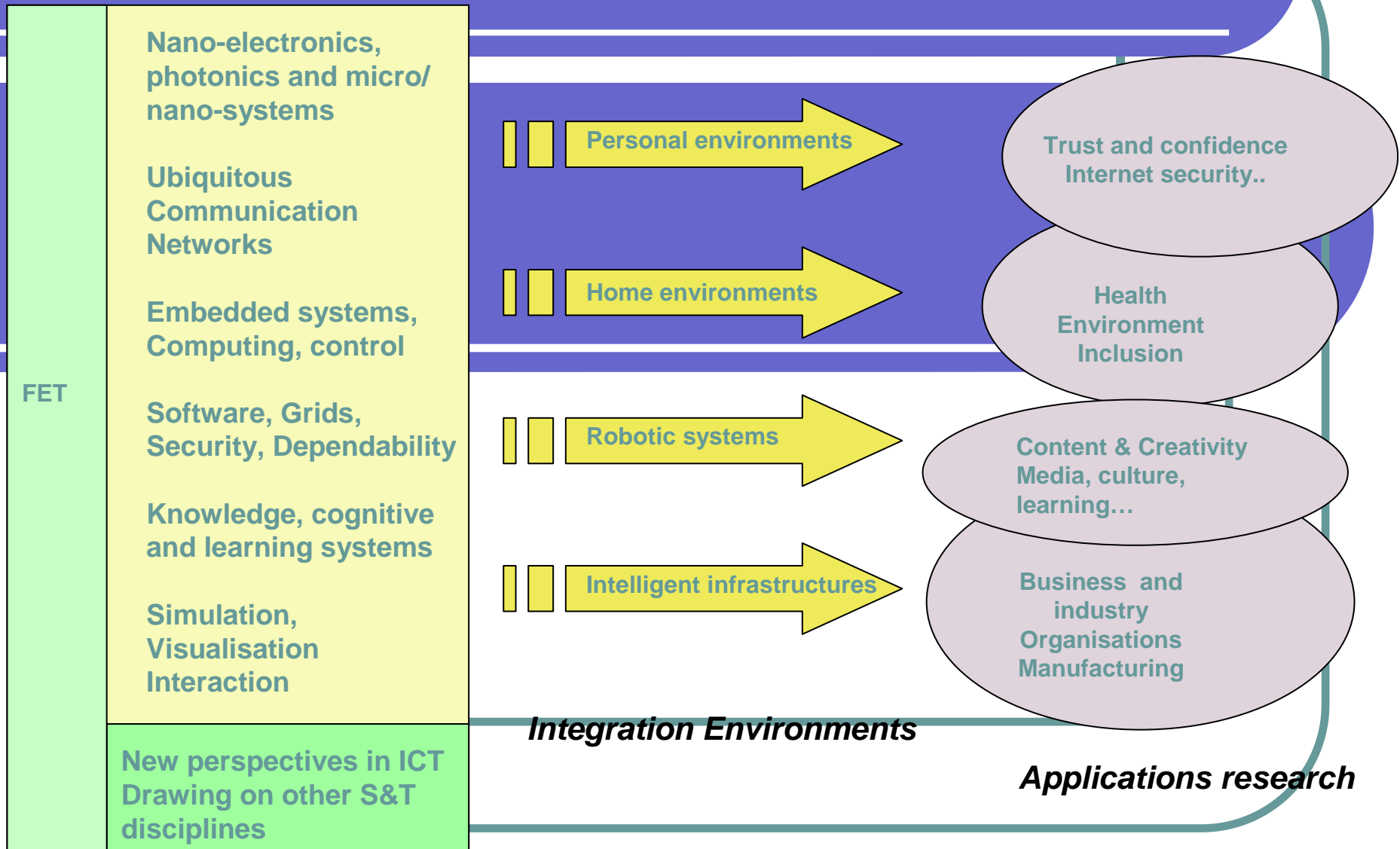

Technology pillars

FP7 – latest

- 1st Call for proposals foreseen for Dec. '06
- # of Calls/year still open issue
- Initially, funding level comparable to FP6 on a yearly basis (2007-2009), then ramp-up until 2013
- Continuity in the funding instruments (IPs, NoEs, STREPS,...)

CONCLUSION

- FET will be an important part in the ICT theme under FP7 (FET in all themes of Specific Pgm « Cooperation »)
- « FET Proactive » and « FET-Open » tracks remain
- Longer-Term, High-Risk, Purpose-driven Collaborative Research is supported at EU level
- Your organizations will play an important role in carrying the ICT Research needed to shape the future Knowledge Society in Europe.